

How To Use Your New Flexible Purge Chamber

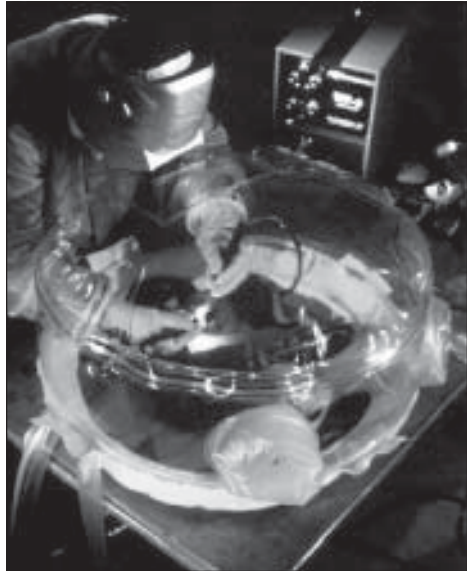

TABLE OF CONTENTS:

Safety Guidelines	2
Warranty	4
Introduction	4
Description	4
Specifications	5
Check list	5
Optional items	6
Suggestions	6
Assembly	6
Installation	6
Operation	7
Questions	7
Technical Data	8

NOTE: *The important safeguards and instructions appearing in this pamphlet should be read and understood prior to operating your equipment.*



January, 2000
CK Worldwide, Inc.
P.O. Box 1636 Auburn, WA, USA 98071
tel: (253) 854-5820
fax: (253) 939-1746
www.ckworldwide.com
ck@ckworldwide.com

SAFETY RULES:



WARNING: UNSAFE PROCEDURES OR PRACTICES CAN CAUSE SERIOUS PERSONAL INJURY OR DEATH.

All end users of this equipment, the operators and helpers, read and understand these safety rules.



PREVENT ELECTRICAL SHOCK:

Touching live electrical parts can cause severe burns or fatal shock.

1. Do not touch live electrical parts.
2. Do not work in wet or damp areas.
3. Wear dry insulating gloves and body protection.
4. Disconnect all power before installing or servicing this equipment.
5. Turn off all equipment when not in use.
6. Properly install and ground the welding power source according to its Owner's Manual and all applicable codes.
7. Do not use worn or damaged cables or cables that are too small or poorly spliced.
8. Do not wrap cables around your body.
9. Do not touch electrode and any grounded object or circuit at the same time.
10. Use only well-maintained equipment. Repair or replace damaged parts at once.



PROVIDE PROTECTION FROM FUMES AND GASES:

Breathing welding fumes and gases can be hazardous to your health.

1. Keep your head out of welding fumes.
2. Use adequate ventilation in the work area to keep fumes and gases from your breathing zone and the general work area.
3. If ventilation is inadequate, use an approved breathing device.
4. Read and understand the Material Safety Data Sheets (MSDSs) and the manufacturer's instructions for any materials used.



PROTECT COMPRESSED GAS CYLINDERS:

Gas cylinders are normally used when welding, treat them with care.

1. Protect compressed gas cylinders from excessive heat, mechanical shocks and arcs.
2. Install and secure cylinders so that they cannot fall or tip over by fastening them to a mounting bracket, wall or other stationary support.
3. Keep cylinders away from any welding or other electrical circuits.
4. Never allow a welding electrode to touch any cylinder.

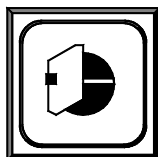

PROTECT EYES AND SKIN FROM ARC RAYS, PROTECT EARS FROM NOISE:

Welding arc rays produce intense heat and ultraviolet rays that can burn eyes and skin. Noise from some processes can also damage hearing.

1. Wear a welding helmet fitted with a proper filter lens (see ANSI Z49.1 for detailed information).
2. Use protective screens or barriers to protect others from welding flash and glare.
3. Wear protective clothing and foot protection.

SAFETY RULES:**PREVENT FIRES AND BURNS:**

The hot workpiece, hot equipment, spatter, and arc sparks can cause fires and burns.

1. Wear correct eye, face, and body protection in the work area.
2. Allow work and equipment to cool before handling.
3. Do not weld near flammable materials.
4. Watch for fire, and keep a fire extinguisher nearby.
5. For additional information, refer to NFPA Standard 51B, "Fire Prevention in Use of Cutting and Welding Processes", available from the National Fire Protection Association, Batterymarch Park, Quincy MA 02269.

**PROVIDE PROTECTION FOR SPECIAL SITUATIONS:**

1. Do not weld or cut containers or materials which have held or been in contact with hazardous substances unless they are properly cleaned and inspected.
2. Do not weld or cut painted or plated parts unless special ventilation is provided to remove highly toxic fumes or gases.
3. Since welding can affect pacemakers, keep all pacemaker wearers out of the work area. Have them consult a doctor before coming near a welding operation.

**PROVIDE PROPER EQUIPMENT MAINTENANCE:**

Improperly maintained equipment can result in poor work, but most importantly it can cause physical injury or death through fires or electrical shock.

1. Always have qualified personnel perform the installation, troubleshooting, and maintenance work. Do not perform any electrical work unless you are fully qualified.
2. Before performing any maintenance work inside a power supply, disconnect the power supply from the electrical power source.
3. Maintain cables, grounding wire, connections, power cord, and power supply in a safe working order. Do not operate any equipment in questionable condition.
4. Do not abuse any equipment or accessories. Keep equipment away from heat sources such as furnaces, wet conditions such as water puddles, oil or grease, corrosive atmospheres, and inclement weather.
5. Keep all safety devices, guards, panels, and covers in position and in good repair.
6. Use equipment for its intended purpose. Do not modify it in any manner.

ADDITIONAL SAFETY INFORMATION:

For more information on safe practices for setting up and operating electric welding and cutting equipment and on good working habits, ask your welding equipment supplier.

For your protection, read and comply with the latest editions of the following standards:

- | | |
|------------------------|-------------------------------------|
| 1. ANSI Standard Z49.1 | 6. NFPA Standard 51B |
| 2. ANSI Standard Z87.1 | 7. NFPA Standard 70 |
| 3. AWS Standard A6.1 | 8. OSHA Standard 29 CFR, Part 1910, |
| 4. AWS Standard F4.1 | Subpart Q |
| 5. CSA Standard W117.2 | |

WARRANTY:

CK Worldwide, inc. warrants the Flexible Purge Chamber against defects in materials and workmanship for a period of one year from the date of purchase. Should it become defective for such reason, the manufacturer will repair it without charge, if it is returned to the manufacturer's factory, freight prepaid. Prior to returning the equipment, written authorization, in the form of an RGA number must be obtained prior to any returns for any reason. This warranty does not cover: (1) failure due to normal wear and tear; (2) damage by accident, improper use, neglect, unauthorized repair or alteration; (3) any one other than the original purchaser. In any event, CK Worldwide, Inc. will only be responsible for its products when used with accessory items manufactured by CK Worldwide, Inc.

This limited warranty is in lieu of all other warranties, expressed or implied. The manufacturer shall not be liable for any injury to persons, including death; or loss or damage to any property, direct or consequential, including, but not limited to loss of use, arising out of the use, or the inability to use, the product. The user assumes all risk and liability whatsoever in connection with the use of this product, and before doing so shall determine its suitability for its intended use, and shall ascertain the proper method of using it. This warranty gives you specific legal rights, and you may have other rights which vary from state to state.

INTRODUCTION:

The patented CK Flexible Purge Chamber is used in the Gas Tungsten Arc Welding (GTAW)/Tungsten Inert Gas (TIG) process to provide a completely inert atmosphere for the welding of reactive metals such as titanium, molybdenum, nickel-based and aluminum-based alloys, as well as non-reactive metals like stainless steel. Unique to this design is the ability to draw a vacuum around the product to be welded which collapses the chamber, removing all atmospheric gases. The chamber is then filled through a perforated hose that covers the circumference of the chamber. This filling process allows the argon gas to expel all atmospheric gases more effectively than traditional filling methods. This significantly reduces the time required to reach a totally inert atmosphere that is suitable for welding and uses considerably less gas than the traditional rigid purge chambers.

DESCRIPTION:

The Flexible Purge Chamber is designed to rest on a support device that is the same diameter as the chamber's base. When the unit is completely deflated, with the chamber's walls draped over the sides of the support base, a vacuum is drawn by either 1.) blowing compressed air through the external vacuum "Y" creating a venturi capable of expelling the atmospheric air inside the chamber, or 2.) installing an auxiliary vacuum pump. Once a vacuum is performed the chamber is then inflated at 35 cubic feet per hour (Excessive fill rates will cause turbulence resulting in the mixing of the argon shielding gas with the air in the chamber which extends the time it takes to obtain a completely inert atmosphere). The purpose is to displace any remaining atmospheric air out the exhaust port on the top of the chamber using argon which is significantly heavier than air. Parts can then be welded in a totally inert atmosphere.

To remain competitive in the domestic and international markets, we are allowing customers to provide their own welding table and other accessories to fit inside the chamber.

SPECIFICATIONS:

FLEXIBLE PURGE CHAMBER:

- Height: 20"
- Width: 30" *
- Shipping Weight: 17 lbs.
- Standard Size*: 30" Diameter
- 30" Range of Movement
- 24" Base

* Contact factory for price and availability on other sizes.

CHECKLIST:

- One (1) Transparent Flexible Purge Chamber Enclosure
- Four (4) Neoprene Gloves - Two (2) Installed
- One (1) Roll of Tape
- One (1) Repair Kit
- One (1) Heat Blanket
- One (1) Venturi
- One (1) Gas Valve Assembly (installed) with Hoses
- One (1) Electric Vacuum Pump
- One (1) Flow-meter / Regulator with Argon hose
- One (1) Storage Container

Transparent Flexible Purge Chamber Enclosure

Neoprene Gloves

Roll of Tape

Repair Kit

Heat Blanket

Venturi

Gas Valve Assembly with Hoses

Vacuum Pump

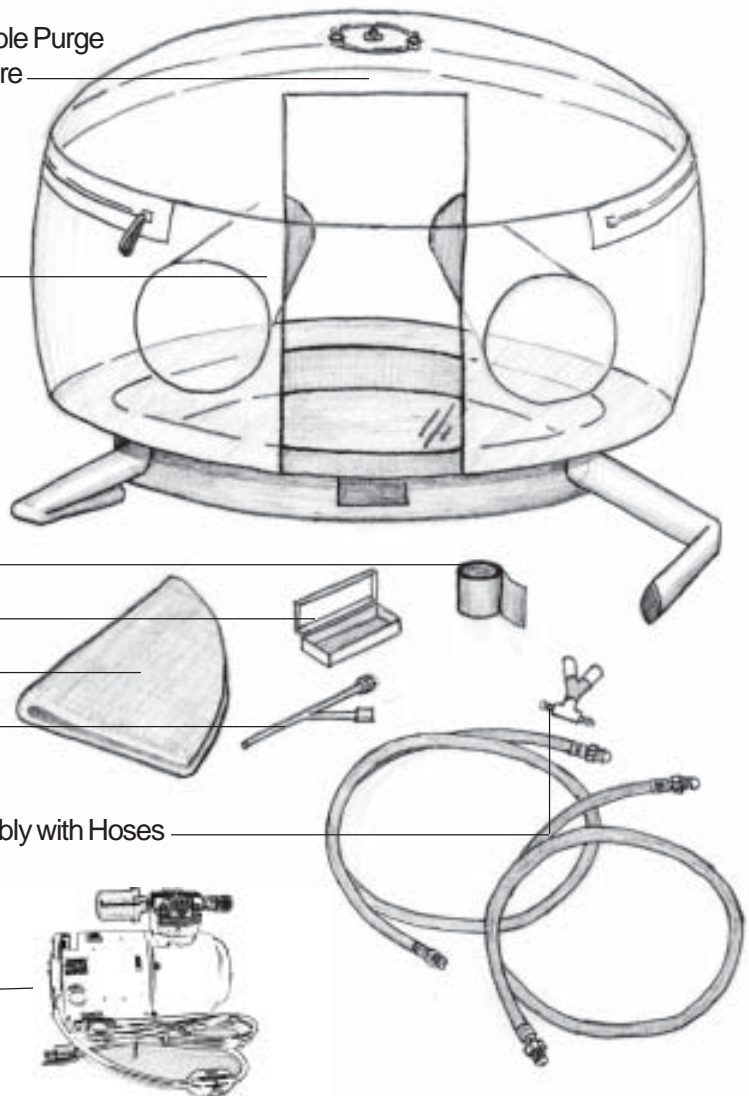

**OPTIONAL
ITEMS:**

TIG Torch and accessories - refer to extra value brochure (form 3000).
Cold Wire Feed Unit.
Extra neoprene gloves.

SUGGESTIONS:

1. If welded parts are too hot to handle, use forced gas cooling with a small fan to speed up the cooling process inside the chamber. Do not use leather gloves inside the chamber, as they can cause contamination.
2. To keep hands comfortable, cotton gloves can be worn inside neoprene gloves.
3. The components being put into the chamber must be cleaned with a suitable solvent and dried. The parts should be handled with clean hands.
4. Do not collapse chamber before parts have cooled.

ASSEMBLY:

If the chamber has been exposed to temperature extremes, it should be left for several hours to reach room temperature. Premature unpacking could lead to cracking, scuffing and/or deformation. The chamber is quoted and normally supplied in its bare form and will need a hard internal base, an external support table, an argon gas supply with flowmeter, compressed air (for vacuum process), a welding torch and ground cable.

Unpack the chamber carefully to avoid cracking, scratching or tearing. Place the chamber on a prepared table top, the same diameter as the inner base ring. At this time the heat blanket should be placed on the plastic base inside the chamber. A steel plate should then be placed on top of the heat blanket. A stainless steel plate is recommended (1/4" - 1/2"). The blankets edges will be exposed around the perimeter inside the chamber, to protect the sides of the chamber.

Note: The heat blanket acts as a low temperature protector that insulates the steel base plate from the plastic base. The blanket is not intended to be welded on.

INSTALLATION:

Insert the torch assembly into the chamber through one of the accessory ports. You will need to pierce a hole at the port entrance of the chamber. Remove all front-end parts from TIG torch. Once the torch has been inserted, use the tape provided, or duct tape, to seal the port sleeve onto the torch cable. The ground cable and other accessories should be installed through one of the accessory ports in the same manner, then sealed.

Connect the gas hose assembly to the chamber at the 1/4" NPT inlet. Next, connect the hose coming from the "Y" labeled "GAS" to a regulator/flowmeter. The unit is now ready to have parts inserted for welding.

OPERATION:

Ensure there is sufficient high purity argon in the purge chamber supply bottle and the torch gas supply bottle to complete all welding operations. Failure to do this will result in the introduction of air during a bottle change which will require re-purging of the system. Check to ensure that all gas lines to the chamber, the welding machine, and regulator/flowmeter are tight. Also, check to ensure that all accessory ports that are in use are properly taped. Check gloves for any damage.

Load the components into the chamber and close the zipper. Purge out the torch lines. The chamber can be pressed down around the parts to expel the majority of the air. Make sure that the exhaust vent on the top of the chamber is closed. To complete the vacuum process, one of two methods can be used: 1.) "Y" Vacuum: Compressed air is blown through the inlet of the "Y" which creates a venturi effect, extracting all of the remaining air in the chamber, or 2.) Electric Vacuum Pump: Plug pump into 115VAC circuit, leave on until all air is vacated from the chamber.

Note: Make sure when performing a vacuum that the vacuum valve is open and the gas valve is closed on the gas "Y".

At this time, turn on argon gas supply, open exhaust valve on top of the chamber, making sure vacuum valve is closed and gas valve is open on gas "Y". The argon flow rate should not exceed 35 cubic feet per hour, otherwise turbulence will cause mixing of the argon shielding gas with the air in the chamber. When the chamber is completely inflated a test weld on a piece of scrap material should be performed. If any discoloration or contamination is present, repeat the purge process.

QUESTIONS:

Any user requiring further advice in any matter concerning installation, operation, maintenance or safety can call or write:

CK Worldwide, Inc.
P.O. Box 1636
Auburn, WA. 98071

tel: + 1 253 854 5820
fax: + 1 253 939 1746
www.ckworldwide.com
ck@ckworldwide.com

TUNGSTEN ELECTRODE SELECTOR CHART:

BASE METAL TYPE	MATERIAL RANGE	DESIRED RESULT	WELDING CURRENT	ELECTRODE TYPE	SHIELD GAS	TUNGSTEN PERFORMANCE CHARACTERISTICS
Aluminum alloys and Magnesium alloys	All	General purpose	ACHF	Pure (EW-P)	Argon	Balls easily, tends to spit at higher currents, used for noncritical welds only.
				Zirconiated (EW-Zr)	Argon	Balls well, high current, little spitting, good arc starts, good stability.
				2% Thoriated (EW-Th2)	75% Argon 25% Helium	Medium erosion rate, high current range, little spitting, good arc starts, good stability.
	Only thin sections	Control penetration	DCRP	2% Ceriated (EW-Ce2)	50% Argon 50% Helium	Lowest erosion rate, widest current range, no spitting, best arc starts, best stability.
				2% Thoriated (EW-Th2)	75% Argon 25% Helium	Medium erosion rate, medium current range, medium spitting, good arc starts, best stability.
	Only thick sections	Increase penetration or travel speed	DCSP	2% Ceriated (EW-Ce2)	Helium	Low erosion rate, wide current range, no spitting, consistent arc starts, good stability.
2% Thoriated (EW-Th2)				75% Argon 25% Helium	Medium erosion rate, medium current range, medium spitting, good arc starts, best stability.	
Copper alloys Cu-Ni alloys and Nickel alloys	All	General purpose	DCSP	2% Thoriated (EW-Th2)	75% Argon 25% Helium	Medium erosion rate, medium current range, medium spit, good arc starts, best stability.
				2% Ceriated (EW-Ce2)	75% Argon 25% Helium	Low erosion rate, wide current range, no spitting, consistent arc starts, best stability.
				Zirconiated (EW-Zr)	Argon	Rapid erosion rate at higher currents, low current range recommended, spitting on starts.
	Only thin sections	Control penetration	ACHF	2% Ceriated (EW-Ce2)	75% Argon 25% Helium	Low erosion rate, wide current range, no spitting, consistent arc starts, good stability.
				2% Thoriated (EW-Th2)	75% Argon 25% Helium	Medium erosion rate, medium current range, medium spitting, good arc starts, best stability.
	Only thick sections	Increase penetration or travel speed	DCSP	2% Ceriated (EW-Ce2)	Helium	Low erosion rate, wide current range, no spitting, consistent arc starts, good stability.
2% Thoriated (EW-Th2)				75% Argon 25% Helium	Medium erosion rate, medium current range, medium spitting, good arc starts, best stability.	
Mild steels Carbon steels Alloy steels Stainless steels and Titanium alloys	All	General purpose	DCSP	2% Thoriated (EW-Th2)	75% Argon 25% Helium	Medium erosion rate, medium current range, medium spitting, good arc starts, best stability.
				2% Ceriated (EW-Ce2)	75% Argon 25% Helium	Low erosion rate, wide current range, no spitting, consistent arc starts, good stability.
				2% Lanthanated (EW-Ce2)	75% Argon 25% Helium	Low erosion rate, widest current range, no spitting, best (DC) arc starts, best stability.
	Only thin sections	Control penetration	ACHF	Zirconiated (EW-Zr)	Argon	Rapid erosion rate at higher currents, low current range recommended, spitting on starts.
				2% Ceriated (EW-Ce2)	75% Argon 25% Helium	Low erosion rate, wide current range, no spitting, consistent arc starts, good stability.
	Only thick sections	Increase penetration or travel speed	DCSP	2% Lanthanated (EW-Ce2)	Helium	Lowest erosion rate, highest current range, no spitting, best (DC) arc starts, best stability.
2% Thoriated (EW-Th2)				75% Argon 25% Helium	Medium erosion rate, medium current range, medium spitting, good arc starts, best stability.	

TECHNICAL INFORMATION CHART:

ELECTRODE DIAMETER (inches)	CUP SIZE	WELDING CURRENT (AMPS) - TUNGSTEN TYPE				ARGON FLOW (CFH) - FERROUS METALS		ARGON FLOW (CFH) - ALUMINUM	
		AC PURE	AC THORIATED	DCSP PURE	DCSP THORIATED	STANDARD BODY	GAS LENS BODY	STANDARD BODY	GAS LENS BODY
.020	4 or 5	5-15	5-20	5-15	5-20	5-8	5-8	5-8	5-8
.040	4 or 5	10-60	15-80	15-70	20-80	5-10	5-8	5-12	5-10
1/16	4, 5 or 6	50-100	70-150	70-130	80-150	7-12	5-10	8-15	7-12
3/32	6, 7 or 8	100-160	140-235	150-220	150-250	10-15	8-10	10-20	10-15
1/8	7, 8 or 10	150-210	220-325	220-330	240-350	10-18	8-12	12-25	10-20
5/32	8 or 10	200-275	300-425	375-475	400-500	15-25	10-15	15-30	12-25
3/16	8 or 10	250-350	400-525	475-800	475-800	20-35	12-25	25-40	15-30
1/4	10	325-700	500-700	750-1000	700-1100	25-50	20-35	30-55	25-45

TUNGSTEN PREPARATION:

END PREPARATION

DCSP (EN)

General Purpose:

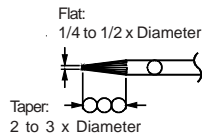

ACHF

General purpose:

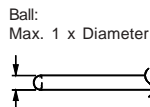

Ball tip by arcing on clean metal at low current DCRP (EP) then slowly increase current to form the desired ball diameter.

GRINDING INSTRUCTIONS

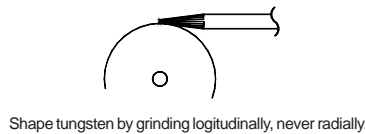

Remove sharp point to leave a truncated point with a flat spot. Diameter of flat spot determines amperage.

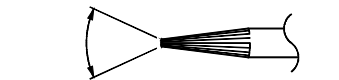

Use a 60 grit or finer aluminum oxide wheel.

EXTENSION INSTRUCTIONS

STANDARD PARTS

General Purpose:

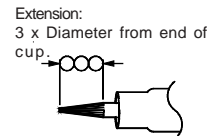

GASLENS PARTS

General Purpose:

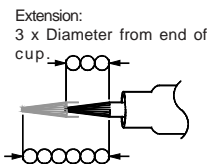

Maximum extension:
6 x Diameter from end of cup.
(In draft-free areas)



Form No. 5702
CK Worldwide, Inc.
P.O. Box 1636 Auburn, WA. 98071
tel: (206) 854-5820
fax: (206) 939-1746