

# WeldTec®

## Stubby™ TIG Torches

“Stubby” Torches offer unprecedented versatility for light duty TIG welding.

- Interchangeable heads
- Light weight and compact
- Better weld puddle control
- Less hand and wrist fatigue

Ten interchangeable heads that can be changed in seconds allowing access to the most difficult weld locations. Ideal for all kinds of intricate welds. One torch body, ten heads.

The soft flexible rubber handle is easy to hold without strain or tension of the hand or wrist.

The super flex rubber power cable is the most flexible in the industry, over braided with non-flammable yarn for durability.



Made in America.

### AIR COOLED - ORDERING INFORMATION

TORCH SERIES	MODEL	AMPS*	TORCH PACKAGE	LENGTH	STD. HEAD
9	WTS-9	125	WTS-9-12SF	12.5 Ft.	920-70
			WTS-9-25SF	25 Ft.	920-70
17	WTS-17	150	WTS-17-12SF	12.5 Ft.	1718-70
			WTS-17-25SF	25 Ft.	1718-70
24	WTS-24	80	WTS-24-12SF	12.5 Ft.	24-70
			WTS-24-25SF	25 Ft.	24-70

### WATER COOLED - ORDERING INFORMATION

TORCH SERIES	MODEL	AMPS*	TORCH PACKAGE**	LENGTH	STD. HEAD
18	WTS-18	200	WTS-18-12R**	12.5 Ft.	1718-70
	WTS-18	200	WTS-18-25R**	25 Ft.	1718-70
20	WTS-20	200	WTS-20-12R**	12.5 Ft.	920-70
	WTS-20	200	WTS-20-25R**	25 Ft.	920-70
24W	WTS-24W	180	WTS-24W-12R**	12.5 Ft.	24-70
	WTS-24W	180	WTS-24W-25R**	25 Ft.	24-70

\*AC, DCSP

R\*\* = Super Flex Over Braided

### INTERCHANGEABLE HEADS

USES WT-9, WT-20 STYLE PARTS

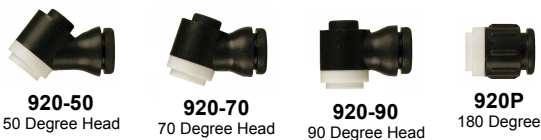

USES WT-17, WT-18 STYLE PARTS



USES WT-24 STYLE PARTS



### TORCH PARTS

Order optional heads, collets, collet bodies gas lens, nozzles, back caps separately. (See replacement parts sheets for details)

Specifications subject to change without notice.

TEC WELDING PRODUCTS, INC. • PO BOX 1870 • SAN MARCOS, CA 92079 • (760) 747-3700  
 COPYRIGHT 2014 - 2015 TEC WELDING PRODUCTS INC.      www.tigtorch.com      e-mail info@tectorch.com

ST1016

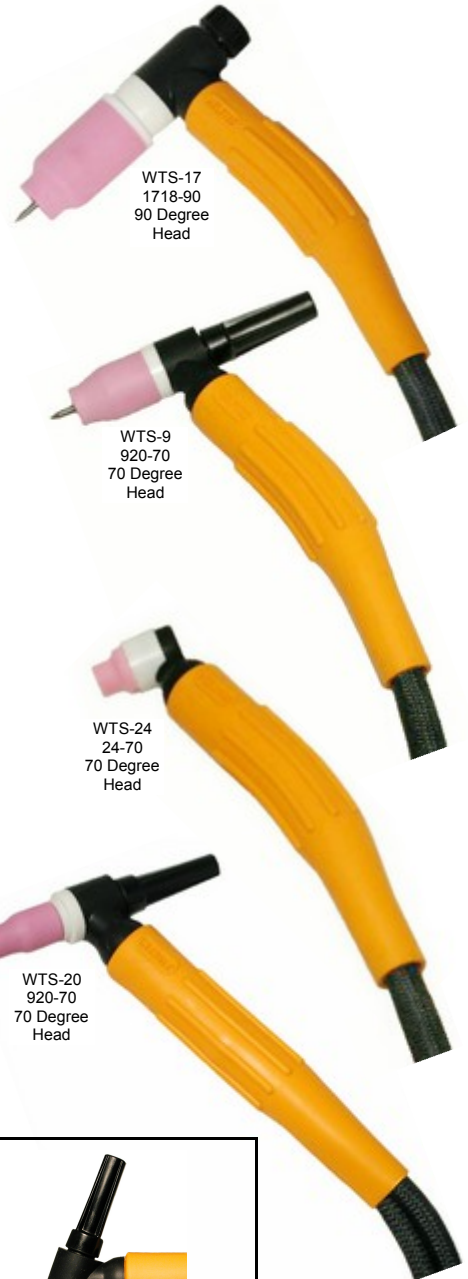

Clear quartz nozzles available. (See flyer)

## REPLACEMENT PARTS

## WTS-9 125 AMPS AIR COOLED

**CAUTION**  
Head must be tightened firmly before starting arc.

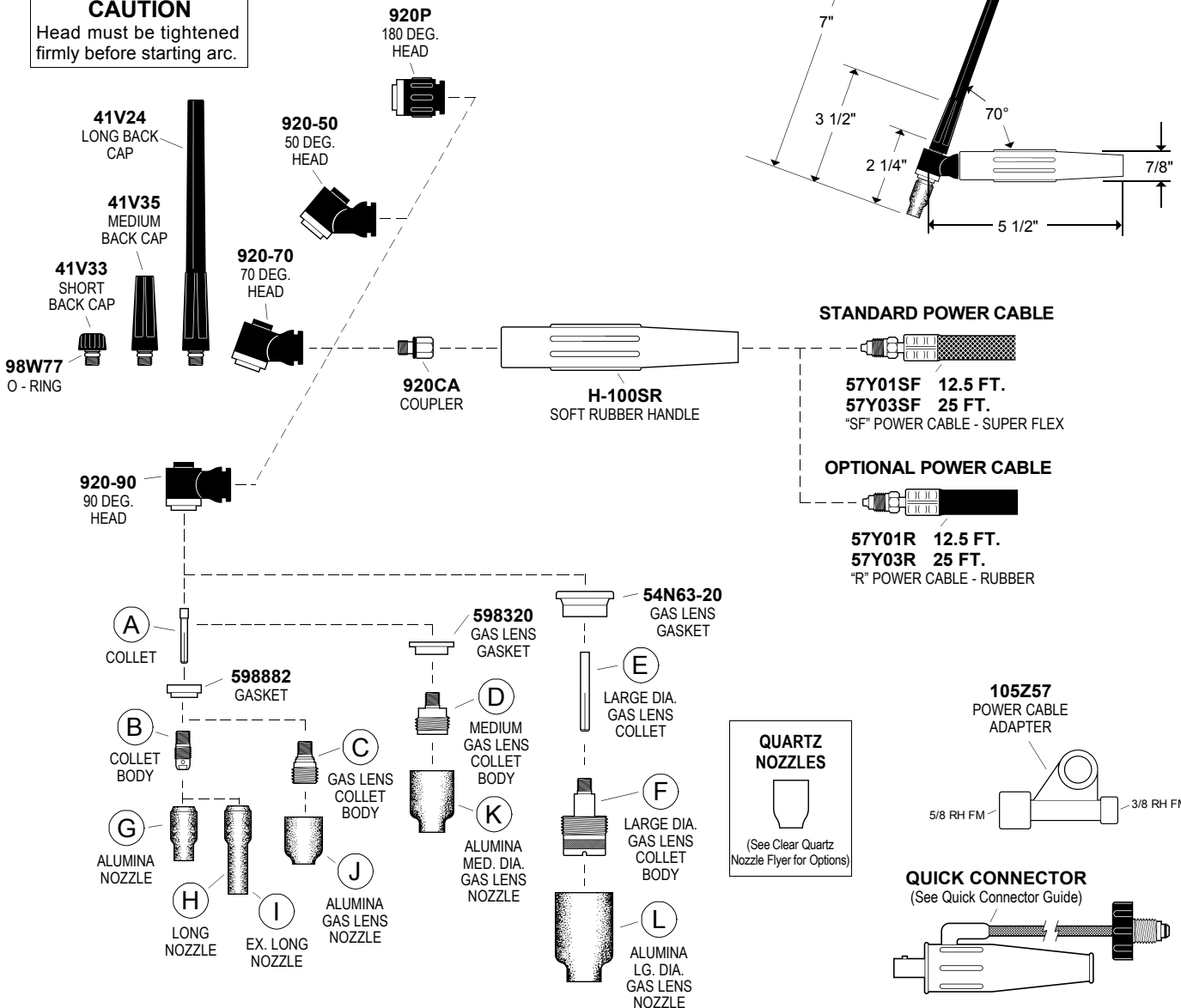
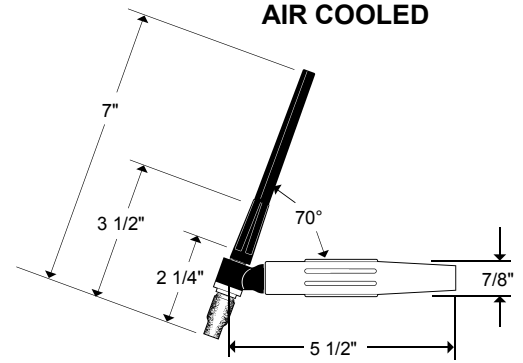

COPYRIGHT 2014 - 2016 TEC WELDING PRODUCTS, INC.

### COLLETS • COLLET BODIES • GAS LENS

### GAS NOZZLES

ITEM	ELECTRODE DIAMETER	.020 0,5	.040 1,0	1/16 1,6	3/32 2,4	1/8 3,2
A	COLLET	13N20	13N21	13N22	13N23	13N24
B	COLLET BODY	13N25	13N26	13N27	13N28	13N29
C	GAS LENS	45V41	45V42	45V43	45V44	45V45
D	MED. DIA. GAS LENS	—	—	45V35SW	45V36SW	45V37SW
E	LG. DIA. GAS LENS COLLET	13N20L	13N21L	13N22L	13N23L	13N24L
F	LG. DIA. GAS LENS	45V0204S		45V116S	45V64S	995795S

ITEM	NO. SIZE	3 3/16"	4 1/4"	5 5/16"	6 3/8"	7 7/16"	8 1/2"	10 5/8"	11 11/16"	12 3/4"
G	ALUMINA	—	13N08	13N09	13N10	13N11	13N12	13N13	—	—
H	LONG 17/8"	796F70	796F71	796F72	796F73	—	—	—	—	—
I	EX. LONG 2 1/2"	796F74	796F75	796F76	796F77	—	—	—	—	—
J	ALUMINA GAS LENS	—	53N58	53N59	53N60	53N61	53N61S	—	—	—
K	ALUMINA MED. DIA. GAS LENS	—	—	—	—	54N15SW	54N14SW	54N12SW	54N19	—
L	ALUMINA LG. DIA. GAS LENS	—	—	—	57N75	—	57N74	53N88	—	53N87*

Specifications and descriptions subject to change without notice.

\* #15 53N89 15/16" ID X 1 7/8" Long