

WeldTec®

Stubby™ TIG Torches

“Stubby” Torches offer unprecedented versatility for light duty TIG welding.

- Interchangeable heads
- Light weight and compact
- Better weld puddle control
- Less hand and wrist fatigue

Ten interchangeable heads that can be changed in seconds allowing access to the most difficult weld locations. Ideal for all kinds of intricate welds. One torch body, ten heads.

The soft flexible rubber handle is easy to hold without strain or tension of the hand or wrist.

The super flex rubber power cable is the most flexible in the industry, over braided with non-flammable yarn for durability.



Made in America.

AIR COOLED - ORDERING INFORMATION

TORCH SERIES	MODEL	AMPS*	TORCH PACKAGE	LENGTH	STD. HEAD
9	WTS-9	125	WTS-9-12SF	12.5 Ft.	920-70
			WTS-9-25SF	25 Ft.	920-70
17	WTS-17	150	WTS-17-12SF	12.5 Ft.	1718-70
			WTS-17-25SF	25 Ft.	1718-70
24	WTS-24	80	WTS-24-12SF	12.5 Ft.	24-70
			WTS-24-25SF	25 Ft.	24-70

WATER COOLED - ORDERING INFORMATION

TORCH SERIES	MODEL	AMPS*	TORCH PACKAGE**	LENGTH	STD. HEAD
18	WTS-18	200	WTS-18-12R**	12.5 Ft.	1718-70
	WTS-18	200	WTS-18-25R**	25 Ft.	1718-70
20	WTS-20	200	WTS-20-12R**	12.5 Ft.	920-70
	WTS-20	200	WTS-20-25R**	25 Ft.	920-70
24W	WTS-24W	180	WTS-24W-12R**	12.5 Ft.	24-70
	WTS-24W	180	WTS-24W-25R**	25 Ft.	24-70

*AC, DCSP

R** = Super Flex Over Braided

INTERCHANGEABLE HEADS

USES WT-9, WT-20 STYLE PARTS

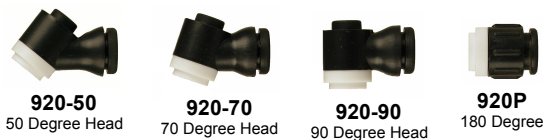

USES WT-17, WT-18 STYLE PARTS



USES WT-24 STYLE PARTS



TORCH PARTS

Order optional heads, collets, collet bodies gas lens, nozzles, back caps separately. (See replacement parts sheets for details)

Specifications subject to change without notice.

TEC WELDING PRODUCTS, INC. • PO BOX 1870 • SAN MARCOS, CA 92079 • (760) 747-3700
 COPYRIGHT 2014 - 2015 TEC WELDING PRODUCTS INC. www.tigtorch.com e-mail info@tectorch.com

ST1016

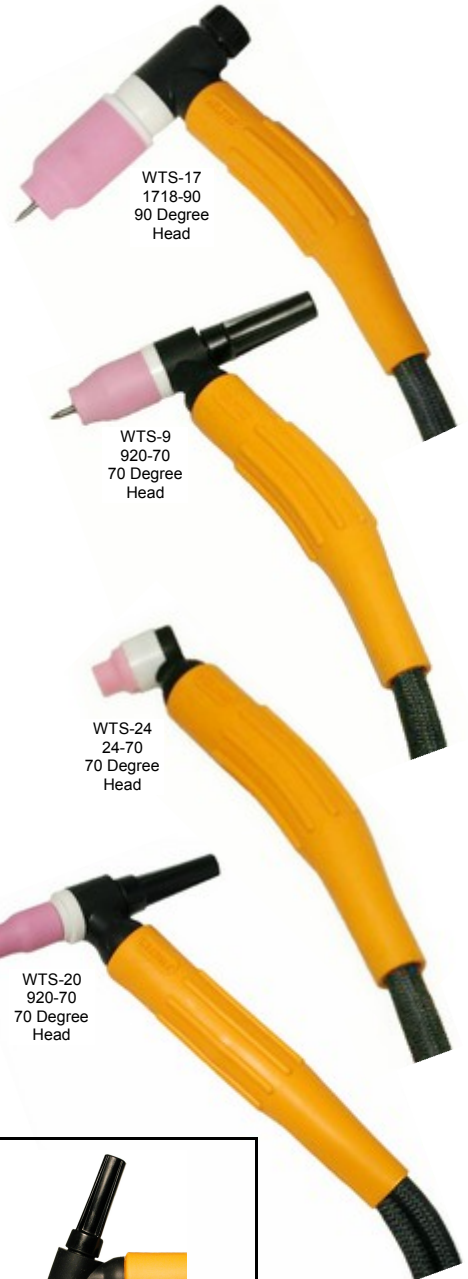

STUBBY™

... by WeldTec®

REPLACEMENT PARTS

WTS-17 150 AMPS AIR COOLED

CAUTION
Head must be tightened firmly before starting arc.

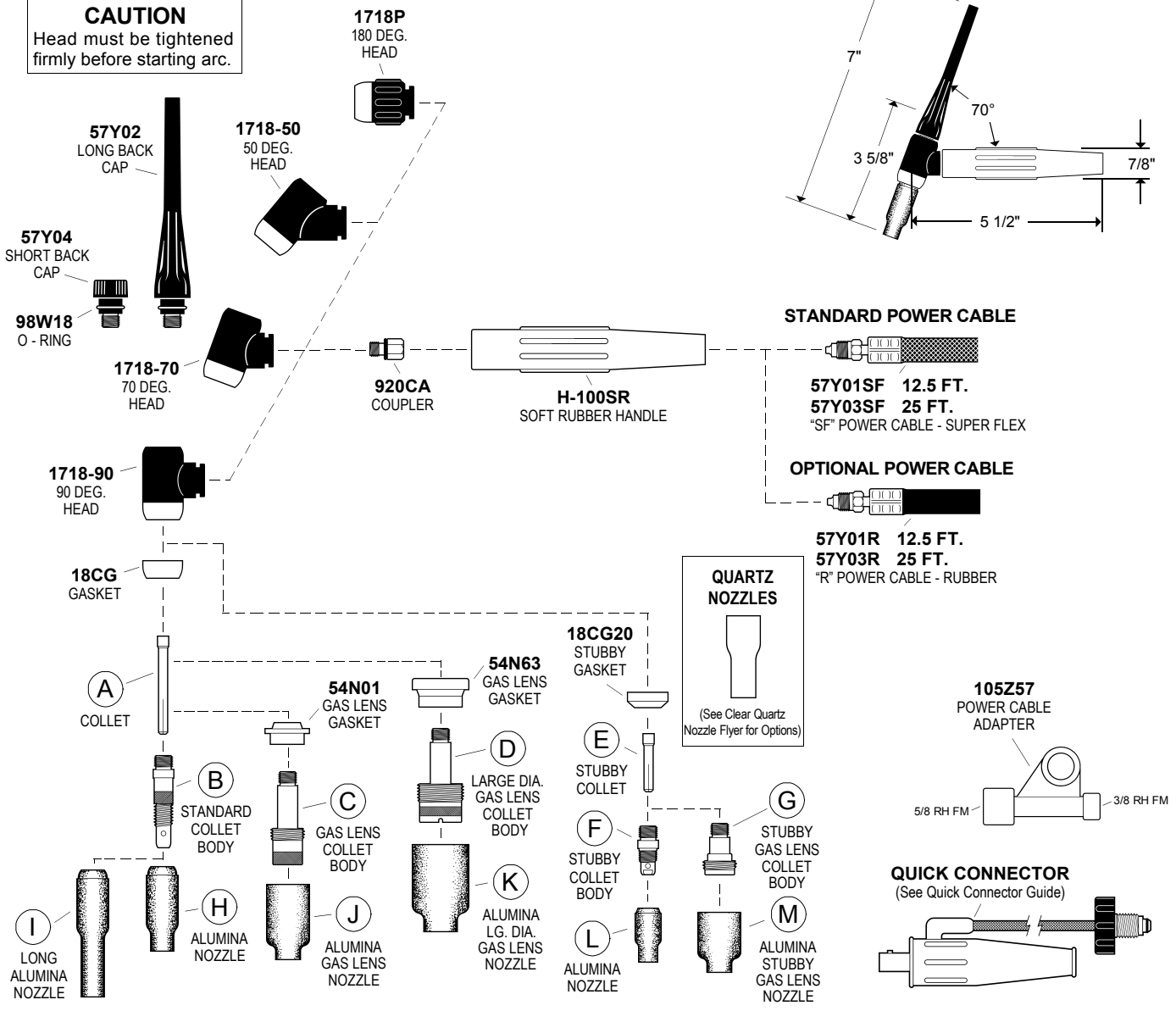
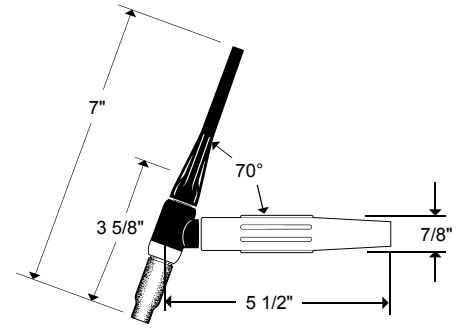

COPYRIGHT 2014 - 2016 TEC WELDING PRODUCTS, INC.

COLLETS • COLLET BODIES • GAS LENS

ITEM	ELECTRODE DIAMETER	.020 0,5	.040 1,0	1/16 1,6	3/32 2,4	1/8 3,2
A	COLLET	10N21	10N22	10N23	10N24	10N25
B	STANDARD COLLET BODY	10N29	10N30	10N31	10N32	10N28
C	GAS LENS	45V29	45V24	45V25	45V26	45V27
D	LG. DIA GAS LENS	—	—	45V116	45V64	995795
E	STUBBY COLLET	—	—	10N23S	10N24S	10N25S
F	STUBBY COLLET BODY	17CB20				
G	STUBBY GAS LENS	—	—	45V25S	45V26S	45V27S

GAS NOZZLES

ITEM	NO. SIZE	4 1/4"	5 5/16"	6 3/8"	7 7/16"	8 1/2"	10 5/8"	11 11/16"	12 3/4"
H	ALUMINA	10N50	10N49	10N48	10N47	10N46	10N45	—	10N44
I	ALUMINA 3" LONG	—	10N49L	10N48L	10N47L	—	—	—	—
J	ALUMINA GAS LENS	54N18	54N17	54N16	54N15	54N14	—	54N19	—
K	ALUMINA LG. DIA. GAS LENS	—	—	57N75	—	57N74	53N88	—	53N87*
L	ALUMINA	13N08	13N09	13N10	13N11	13N12	13N13	—	—
M	ALUMINA STUBBY GAS LENS	—	—	—	54N15SW	54N14SW	54N12SW	54N19	—

* #15 53N89 15/16" ID X 1 7/8" Long

Specifications and descriptions subject to change without notice.

MANUFACTURED IN USA

TEC WELDING PRODUCTS, INC. • PO BOX 1870 • SAN MARCOS, CA 92079 • (760) 747-3700

www.tectorch.com

e-mail info@tectorch.com

www.weldtec.com

REVISION B