

WARRANTY: CK Worldwide, Inc. warrants products manufactured by CK Worldwide, Inc. to be free of defects in materials and workmanship. CK Worldwide, Inc. limits this warranty to replacement of the product or parts thereof and excludes liability for injury, property damage or economic loss attributable to product use or misuse. In any event, CK Worldwide, Inc. will only be responsible for its products when used with accessory items manufactured by CK Worldwide, Inc.

INSTALLATION: Before using this torch, - tighten regulator, hose and power cable fittings with proper wrenches. Using small pliers, securely tighten all knurled hose fittings (Slide the torch handle back for access to the torch connections). Purge the regulator and TIG torch with inert gas at 20 cubic feet per hour. Following these steps will ensure contamination free welds. Repeat this procedure whenever torch or regulator fittings have been detached.

CONNECTION DIAGRAM:

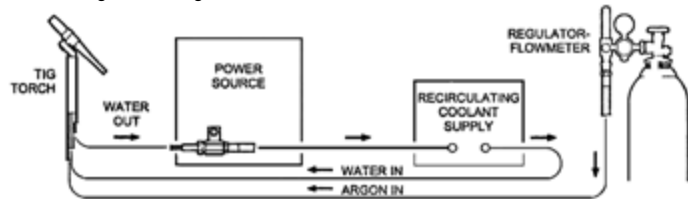

INFORMATION CHART:

Electrode Diameter in inches (mm)	Cup Size	WELDING CURRENT (AMPS) - TUNGSTEN TYPE				ARGON FLOW - FERROUS METALS		ARGON FLOW - ALUMINUM	
		AC Pure	AC Thoriated	DCSP Pure	DCSP Thoriated	Standard Body (Liters)	Gas Lens Body (Liters)	Standard Body (Liters)	Gas Lens Body (Liters)
.020 (0.50)	4 or 5	5 - 15	5 - 20	5 - 15	5 - 20	5-8 (3-4)	5-8 (3-4)	5-8 (3-4)	5-8 (3-4)
.040 (1.00)	4 or 5	10 - 60	15-80	15 - 70	20 - 80	5-10 (3-5)	5-8 (3-4)	5-12 (3-6)	5-10 (3-5)
1/16 (1.60)	4, 5 or 6	50 - 100	70 - 150	70 - 130	80 - 150	7-12 (4-6)	5-10 (3-5)	8-15 (4-7)	7-12 (4-6)
3/32 (2.40)	6, 7 or 8	100 - 160	140 - 235	150 - 220	150 - 250	10-15 (5-7)	8-10 (4-5)	10-20 (5-10)	10-15 (5-7)
1/8 (3.20)	7, 8 or 10	150 - 210	220 - 325	220 - 330	240 - 350	10-18 (5-9)	8-12 (4-6)	12-25 (6-12)	10-20 (5-10)
5/32 (4.00)	8 or 10	200 - 275	300 - 425	375 - 475	400 - 500	15-25 (7-12)	10-15 (5-7)	15-30 (7-14)	12-25 (6-12)
3/16 (4.80)	8 or 10	250 - 350	400 - 525	475-800	475-800	20-35 (10-17)	12-25 (6-12)	25-40 (12-19)	15-30 (7-14)
1/4 (6.40)	10	325 - 700	500 - 700	750 - 1000	700 - 1100	25-50 (12-24)	20-35 (10-17)	30-55 (14-26)	25-45 (12-21)

TUNGSTEN PREPARATION:

END PREPARATION: DCSP (EN)
General Purpose:

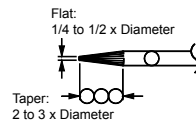

ACHF
General Purpose:

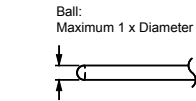

Ball tip by arcing on clean metal at low current DCRP (EP) then slowly increase current to form the desired ball diameter.

GRINDING PREPARATION:
Use a 60 Grit or finer aluminum oxide wheel

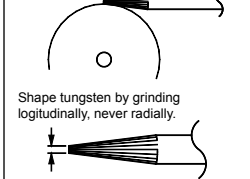

Remove sharp point to leave a truncated point with a flat spot. Diameter of flat spot determines amperage.

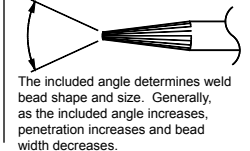

EXTENSION INSTRUCTION: STANDARD PARTS
General Purpose:

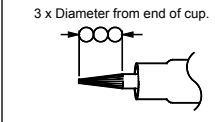

GAS LENS PARTS
General Purpose:

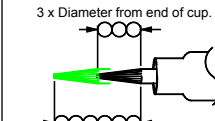

Maximum extension: 6 x Diameter from end of cup. (In draft - free areas)

CAUTION: Personal harm will result from touching the hot parts of a TIG torch without insulative protection, or from looking directly or indirectly at an arc or reflected arc. At no time should bare skin be exposed to a welding arc.



TIG TORCH MANUAL



CKM230

TECHNICAL INFORMATION

RATING @ 100% DUTY CYCLE: 230 AMP ACHF OR DCSP
COOLING METHOD: WATER COOLED

ACCESSORY ITEMS REQUIRED FOR COMPLETE INSTALLATION:

HEAD ACCESSORIES: 2 SERIES HEAD ACCESSORIES
POWER CABLE ADAPTOR: 45V11 (2PCA)

MODEL SELECTOR - TORCH PACKAGES

Torch Style	Cable Style	Cable Length	Standard Part #	Superflex Part #
Straight	3 Piece	12-1/2 ft. (3.81 m)	CKM2312	CKM2312SF
		25 ft. (7.63 m)	CKM2325	CKM2325SF

IMPORTANT !!
READ AND UNDERSTAND THE INFORMATION CONTAINED IN THIS MANUAL BEFORE OPERATING THE EQUIPMENT !

PARTS:

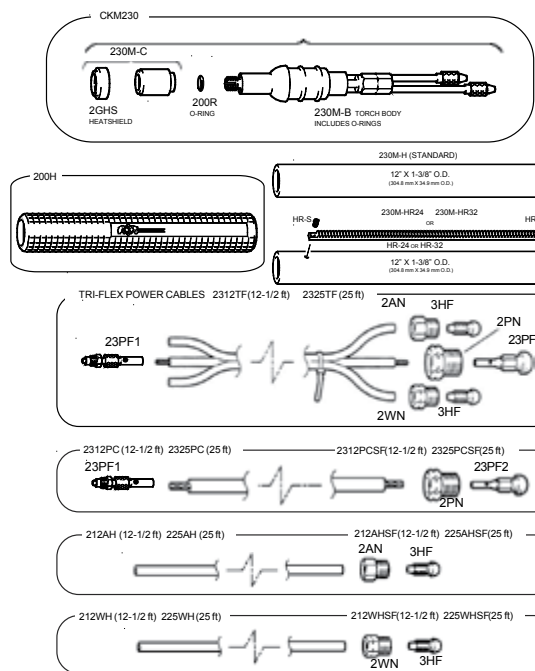

PART #	DESCRIPTION
TORCH	
CKM230	TORCH BODY (WITH HEATSHIELD, COLLET TIGHTENER & O-RING)
230M-H	STANDARD HANDLE (OTHER OPTIONS DISPLAYED)
TRI-FLEX POWER CABLE	
2312TF	TRI-FLEX POWER CABLE & HOSE ASSEMBLY -12-1/2 FOOT (INCLUDES FITTINGS)
2325TF	TRI-FLEX POWER CABLE & HOSE ASSEMBLY -25 FOOT (INCLUDES FITTINGS)
01-0032	CABLE TIE
2AN	GAS HOSE NUT
23PF1	POWER CABLE FITTING
23PF2	POWER CABLE FITTING
2PN	POWER CABLE NUT
2WN	WATER HOSE NUT
3HF	HOSE FITTING (2 REQUIRED)
INDIVIDUAL CABLE HOSES	
212AH	GAS HOSE-12-1/2 FOOT (INCLUDES FITTINGS)
212AHSF	GAS HOSE-12-1/2 FOOT (INCLUDES FITTINGS)
2312PC	POWER CABLE-12-1/2 FOOT (INCLUDES FITTINGS)
2312PCSF	POWER CABLE-12-1/2 FOOT (INCLUDES FITTINGS)
212WH	WATER HOSE-12-1/2 FOOT (INCLUDES FITTINGS)
212WHSF	WATER HOSE-12-1/2 FOOT (INCLUDES FITTINGS)
2312TF	TRI-FLEX WATER, GAS, AND POWER-12-1/2 FOOT SUPERFLEX WATER, GAS, AND POWER-12-1/2 FOOT
2312SF	TRI-FLEX WATER, GAS, AND POWER-12-1/2 FOOT SUPERFLEX WATER, GAS, AND POWER-12-1/2 FOOT
225AH	GAS HOSE-25 FOOT (INCLUDES FITTINGS)
225AHSF	GAS HOSE-25 FOOT (INCLUDES FITTINGS)
2325PC	POWER CABLE-25 FOOT (INCLUDES FITTINGS)
2325PCSF	POWER CABLE-25 FOOT (INCLUDES FITTINGS)
225WH	WATER HOSE-25 FOOT (INCLUDES FITTINGS)
225WHSF	WATER HOSE-25 FOOT (INCLUDES FITTINGS)
2325TF	TRI-FLEX WATER, GAS, AND POWER-25 FOOT SUPERFLEX WATER, GAS, AND POWER-25 FOOT
2325SF	TRI-FLEX WATER, GAS, AND POWER-25 FOOT SUPERFLEX WATER, GAS, AND POWER-25 FOOT
ACCESSORIES	
2PCA (45V11)	POWER CABLE ADAPTER (ORDER SEPARATELY)
SLWHAT-T	SAFE LOCK QUICK CONNECT TWECCO POWER CABLE ADAPTER
SLWHAT-25	DINSE 25 POWER CABLE ADAPTER
SLWHAT-35	DINSE 35 POWER CABLE ADAPTER
SLWHAT-35M	DINSE 35 FLOW-THRU GAS POWER CABLE ADAPTER
200R	O-RING
200M	BACKCAP
2GHS	HEATSHIELD

NOTE:
TRI-FLEX CABLE CAN BE SEPARATED TO REPLACE GAS HOSE, WATER HOSE OR POWER CABLE INDIVIDUALLY

2 SERIES HEAD ACCESSORIES GAS SAVER

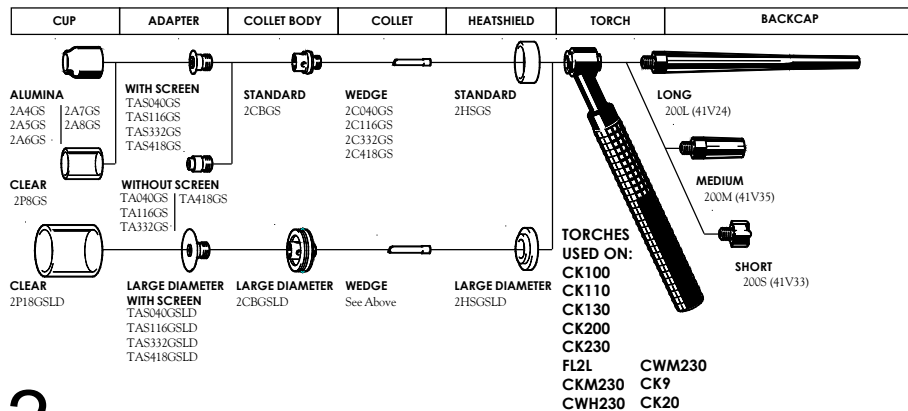

2

2 SERIES HEAD ACCESSORIES

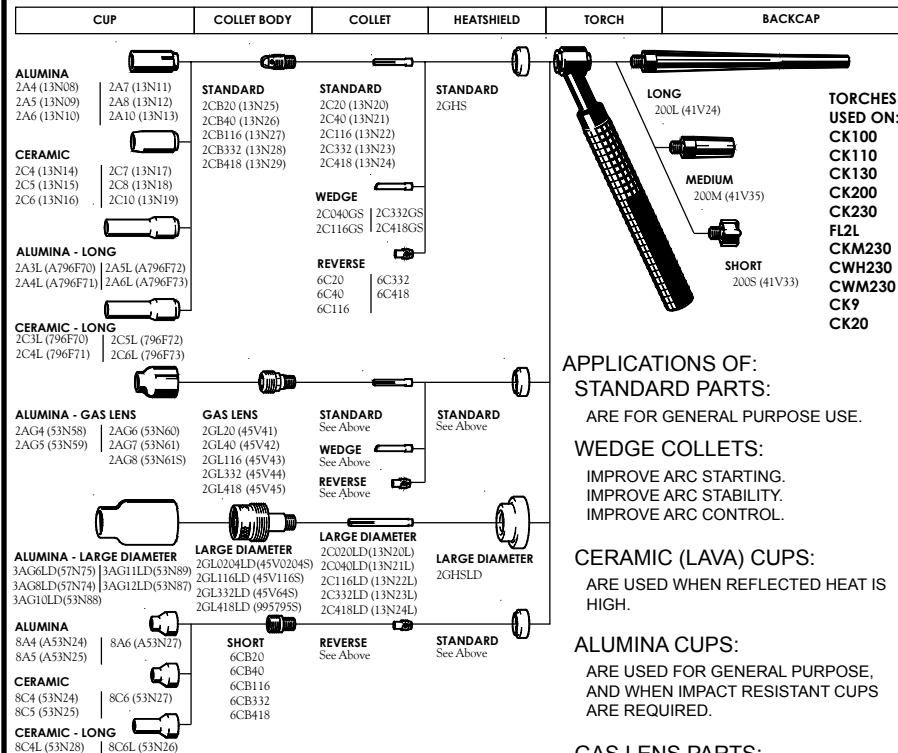

TORCHES USED ON:
CK100
CK110
CK130
CK200
CK230
FL2L
CKM230
CWH230
CWM230
CK9
CK20

APPLICATIONS OF: STANDARD PARTS:
ARE FOR GENERAL PURPOSE USE.

WEDGE COLLETS:
IMPROVE ARC STARTING.
IMPROVE ARC STABILITY.
IMPROVE ARC CONTROL.

CERAMIC (LAVA) CUPS:
ARE USED WHEN REFLECTED HEAT IS HIGH.

ALUMINA CUPS:
ARE USED FOR GENERAL PURPOSE, AND WHEN IMPACT RESISTANT CUPS ARE REQUIRED.

GAS LENS PARTS:
ARE USED TO REDUCE TURBULENCE AND IMPROVE SHIELD GAS COVERAGE PATTERNS, INCREASES DUTY CYCLE OF TORCH AND INCREASES TUNGSTEN STICK OUT.

SHORT (STUBBY) PARTS:
ARE USED TO SHORTEN THE OVERALL LENGTH OF THE TORCH HEAD. REDUCES DUTY CYCLE OF TORCH

GAS SAVER® PARTS:
ARE USED TO SAVE UP TO 40% ON GAS CONSUMPTION.
ARE USED TO SAVE UP TO 60% ON CONSUMABLE PARTS.
ARE USED TO CLEARLY SEE THE WELD PUDDLE.
ARE USED TO ACHIEVE GAS LENS

TUNGSTEN ELECTRODE CONVERSION CHART

Size Suffix	Inches	Millimeters
020	.020"	.5mm
040	.040"	1.0mm
116	1/16"	1.6mm
332	3/32"	2.4mm
418	1/8"	3.2mm
532	5/32"	4.0mm

3